

VAARU TITANIUM STEM

Fitting Instructions
Version:1
2017



Important Note: Steerer tubes must extend through the Vaaru stem completely for proper clamping pressure. It is necessary to have 2mm minimum of steerer tube extended above the stem together with the use of a minimum 5mm headset spacer between the Vaaru stem and headset cap for ALL carbon steerer tube forks. See figure 2. Ensure that the steerer tube is clean and free of burrs or chips before installing the Whyte stem onto steerer tube.

2. The headset should be installed as per the headset manufacturer's instructions.

3. Before assembling the parts, make sure they are all clean from dirt and have been thoroughly de-greased. If it is steerer tube is carbon fibre, apply small amount of carbon fibre assembly gel onto it. Then install the stem body ① onto the steerer tube. Apply anti-seize grease to the stem fixing bolts ② (or ti-prep if titanium bolts).

Tighten the stem fixing bolts ② by alternating between bolts 1/4 turn at a time so both bolts reach proper torque simultaneously. DO NOT go above 6nm. If two fixing bolts go over the maximum torque, the stem clamps may touch slightly (as shown in view A, figure 1). This is NOT PERMISSIBLE since it will compromise the strength of the joint, reducing it's service life and may cause injury or death to persons or damage to property as a result.

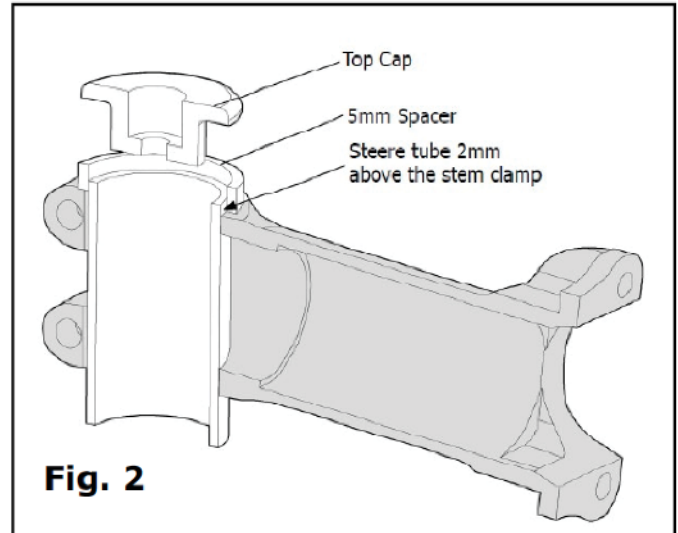

HANDLEBAR INSTALLATION TO STEM

1 Before assembling the parts, make sure they are all clean from dirt and have been thoroughly de-greased. Insert handlebar between stem body ① and face plate ③.

2. Apply anti-seize grease to faceplate bolts (or ti-prep if titanium bolts) and insert them through the four holes in the face plate ③. Use markings on front of handlebar to centre it in the stem. Adjust the angle of handlebar to the desired position and then tighten the stem steerer fixing bolts ② 1/4 turn at a time in an X-pattern to tighten faceplate evenly on handlebar, see figure 3. DO NOT go above maximum torque rating displayed on the stem. This is NOT PERMISSIBLE since it will compromise the strength of the joint, reducing it's service life and may cause injury or death to persons or damage to property as a result. Check handlebar for slippage before each ride to ensure safe operation.

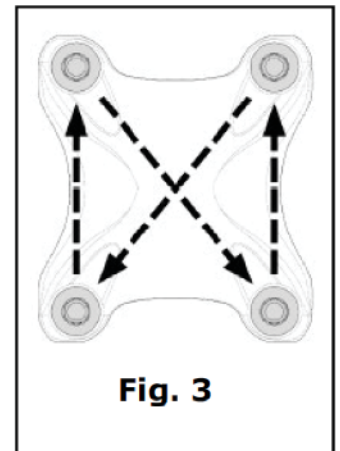

WARNINGS

Be sure to choose the correct stem to fit the steer tube and handlebar for which it is to be installed. Installing the stem on an incorrect steerer tube, or handlebar clamp diameter may cause injury or death to persons or damage to property as a result.

Measure Fork Steerer tube and handlebar clamp area before installing stem. Use an accurate measuring device such as a caliper or micrometer. Installing stem onto an undersized steertube or handlebar can cause stem or bar to slip causing loss of control of bicycle; resulting in an accident, damage to bicycle, injury or death.

INTRODUCTION

Thanks for choosing to purchase this Vaaru product. We hope you will enjoy all the benefits its advanced design

and engineering will bring to your riding experience.

Please read and follow these instructions carefully. Failure to comply with the warnings and instructions could

result in damage to this product that is not covered under warranty. Also possible damage to bicycle; or cause an accident resulting in injury or death.

Please remember, if you are in any doubt about your ability to safely install, service or repair this Vaaru component, do not use it and instead arrange for a qualified bicycle mechanic at your local Bicycle shop to do the job correctly. Vaaru Ltd assumes no responsibility for damages or injury related to improperly installed components.

WARRANTY

Vaaru Ltd warrants all Vaaru products to be free from defects in materials or workmanship for a period of two years after original purchase unless otherwise stated in the full warranty policy. The warranty is non-transferable and valid to the original purchaser of the product only. Any attempt to modify the product in any way such as drilling, grinding, and painting will void the warranty. For more information on warranty policy and instructions for completing a warranty claim, check out the Warranty Policy found at our website: www.vaarucycles.com

SPECIFICATION

Vaaru branded stems are compatible with industry standard steerer tube and handlebar diameters. To choose the correct stem, first measure the specific outer diameter of steerer tube and handlebar to be used. Then check these dimensions are the same 1.1/8" steerer tube and 31.8mm diameter handlebar.

WARNING: Vaaru stems are NOT recommended for use with a handlebar that is over 710mm in length.

COMPONENTS

The assembly order is shown in figure 1:

- ① Stem Body x 1
- ② Fixing Bolts x 6
- ③ Stem Face Plate x 1
- ④ Steerer tube (Front fork) x 1

STEM INSTALLATION TO FORK STEERER TUBE

Tools Required: 4mm A/F bit fitted to a 3-15 Nm Torque Wrench.

1. Measure the diameter of the steerer tube ④ to be certain it is the correct size for installation.

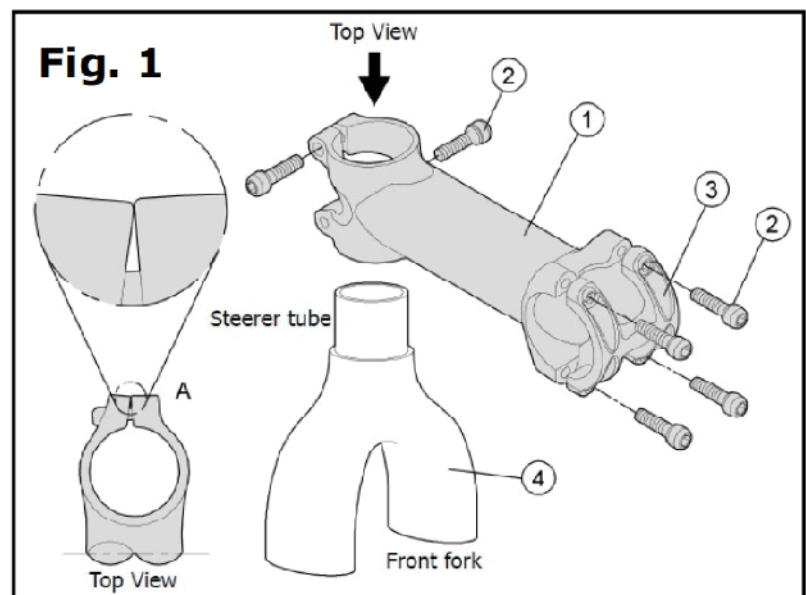

The steerer tube may have to be cut to length. This operation should be performed by a qualified bicycle mechanic at your local bicycle shop.